

SDB SERIES PERIPHERAL PUMP

Performance Table

Model	HP	KW	DNA/DNM	Q.Max L/min	H.Max m	Q. m ³ /h	FLOWRATE					Weight kg
							0	0.6	1.2	1.8	2.4	
SDB60	0.5	0.37	1" / 1"	40	38	H(m)	38	28	18.2	9		5.8
SDB70	0.75	0.55	1" / 1"	45	55		55	46	35	22	9	9.2
SDB80	1	0.75	1" / 1"	46	65		65	55	42	29	14	10.5

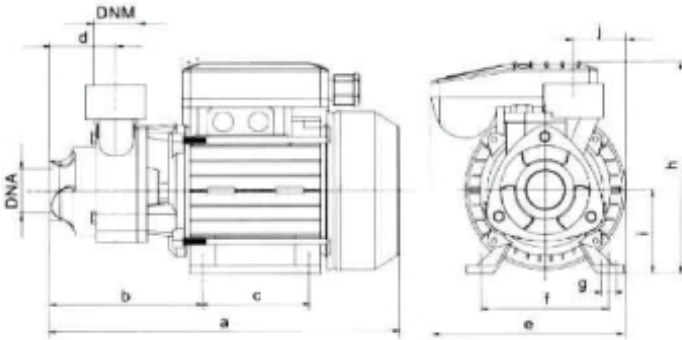

SDB Pump Performance Curve

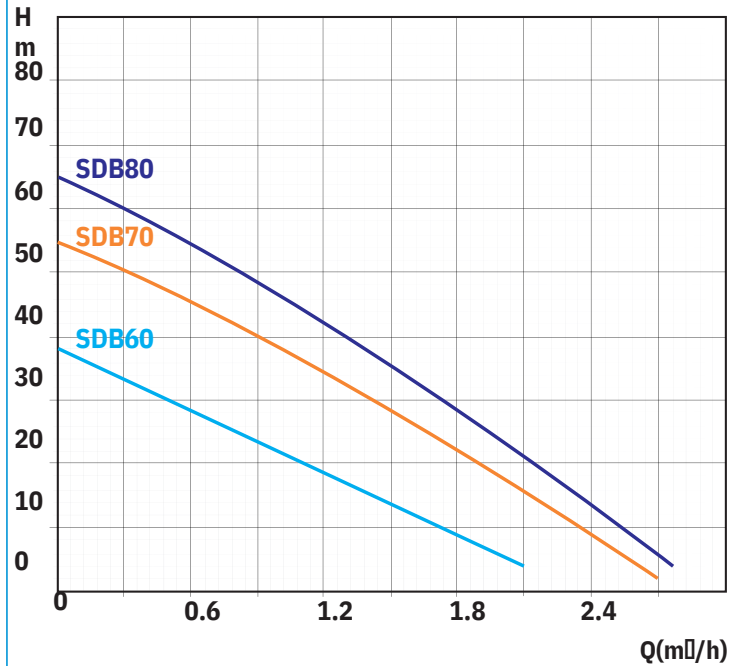

Model	Dimensions (mm)											
	DNA	DNM	a	b	c	d	e	f	g	h	i	j
SDB60	1"	1"	305	120	90	55	146	100	11	160	71	40
SDB70	1"	1"	305	120	90	55	146	100	11	160	71	40
SDB80	1"	1"	305	120	90	55	146	100	11	160	71	40

Features

- ✓ Brass Impeller.
- ✓ Copper Winding.
- ✓ Silent Operation.

