

## SCPM SERIES CENTRIFUGAL PUMP

Performance Table

Model	HP	KW	DNA/DNM	Q.Max L/min	H.Max m	Q. m <sup>3</sup> /h	FLOWRATE						Weight kg
							0	1.2	2.4	3.6	4.8	6.0	
SCPM146	0.75	0.55	1" / 1"	90	25	H(m)	25	23	19	14	7		14
SCPM158	1	0.75	1" / 1"	100	30		30	28.5	25	20	12.3	2	14
SCPM180	1.5	1.1	1 1/4" - 1"	105	37		37	34	30	24	17	6.5	19
SCPM200	2	1.5	1 1/4" - 1"	105	43		43	40	35	28	19	7	20

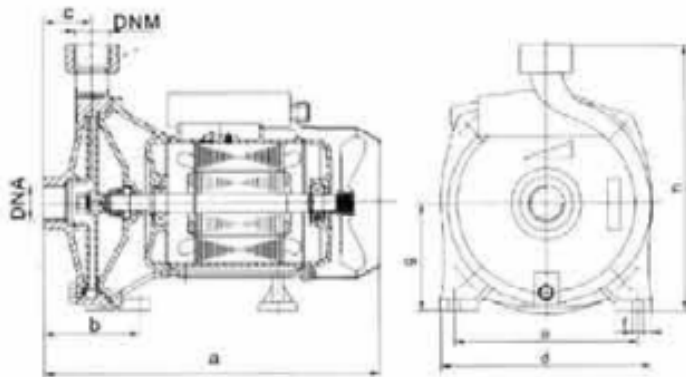

SCPM Pump Performance Curve

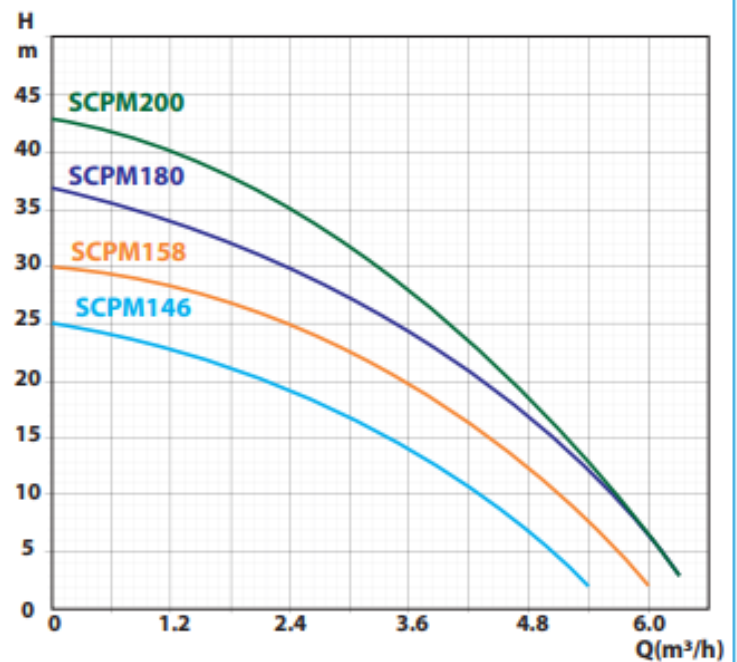

Model	Dimensions (mm)									
	DNA	DNM	a	b	c	d	e	f	g	h
SCPM146	1"	1"	294	82	47	175	142	10	90	224
SCPM158	1"	1"	310	82	43	192	161	10	95	248
SCPM180	1"/1.25"	1"	345	82	56	215	180	12	112	278
SCPM200	1"/1.25"	1"	350	82	55	230	200	12	120	300

### Features

- ✓ 100% Copper Winding.
- ✓ Brass Impeller.
- ✓ Built-in Thermal Protection.
- ✓ NSK Bearing.

